

Séries BPX	SIZE 8 COCENTRIC TWINAX PIN CONTACT FRONT RELEASE, REAR REMOVABLE	Issue:	Page
	CABLE P/N: S280W502_1 BOEING P/N: S280W552_201	29 APRIL 94	1 / 1

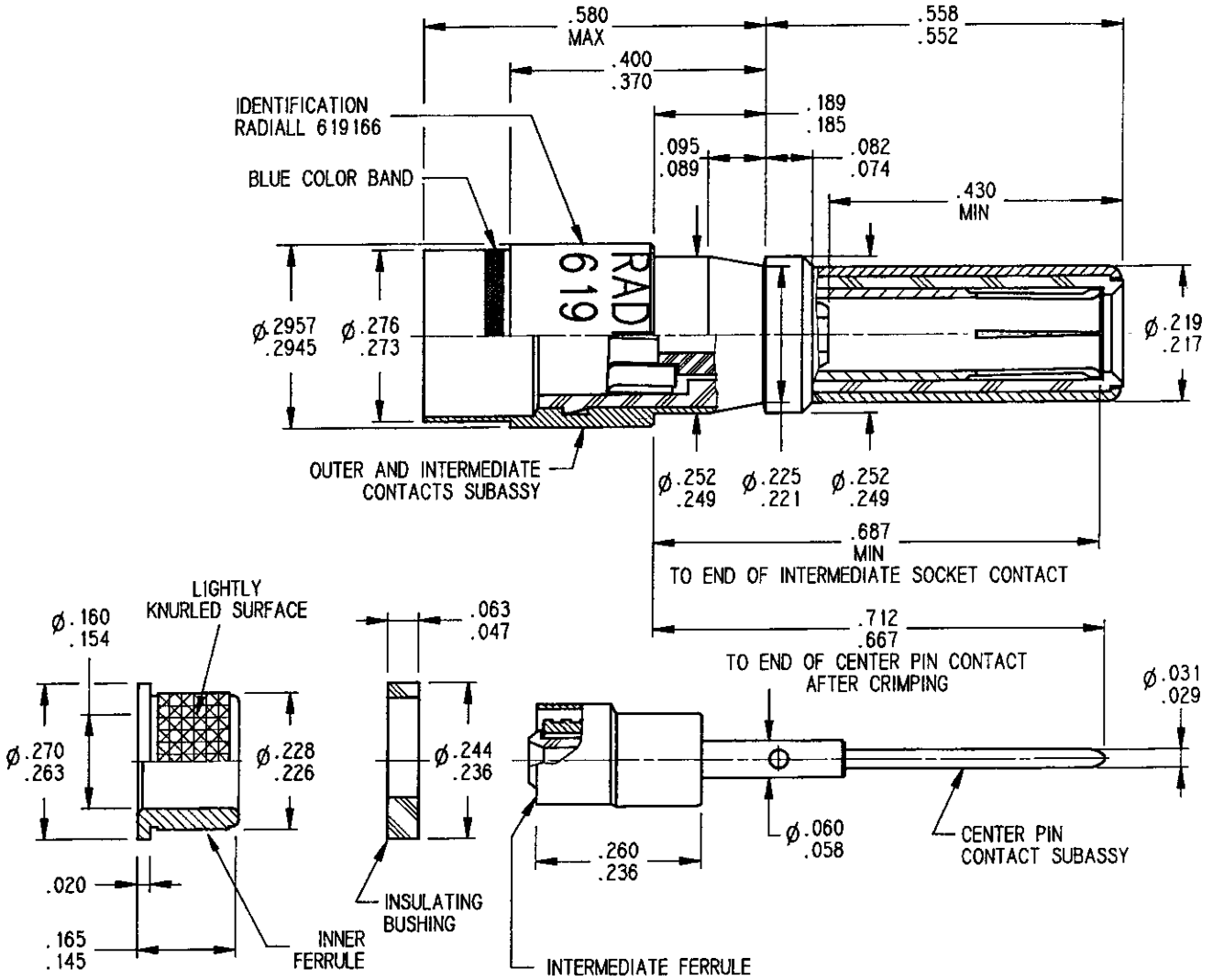

MATERIALS:

OUTER, CENTER CONTACTS, FERRULE AND INNER FERRULE: BRASS PER QQ_B_626
 INTERMEDIATE CONTACT: BERYLLIUM COPPER ALLOY PER QQ_C_530 HEAT TREATED FOR SPRING TINES
 OUTER DIELECTRIC: ULTEM
 CENTER DIELECTRIC AND INSULATING BUSHING: TPFE

FINISHES (ALL METAL PARTS)

GOLD PLATE PER MIL_G_45204, TYPE II, GRADE C, CLASS 1 50 MICROINCHES OVER NICKEL PLATE PER QQ_N_290, CLASS 2

SEE WIRING INSTRUCTIONS: RP08820

This information is given as an indication in the continual goal to improve our products, we reserve the right to make any modifications judged necessary.

CREATION				
PEN: .				
NOM: JP MACARI				
DATE: 29 APRIL 94				
APPR: <i>JP Macari</i>				
Issue	Revisions	Name	Approved	

XXXXXXX